

PEARSON™ POWERLINE RIPPLE DETECTOR PRD-120

- Accurate measurement of audio frequency (CS101) ripple injected on AC or DC power buses
- Separates injected ripple from the power waveform.
- Used with a spectrum analyzer, simplifying the measurement process.
- Maximum voltage, 120 Volts AC or DC
- Switch-selectable frequency response:
 - Flat response from 10 Hz to 150 kHz
 - CS101 profile for setting the ripple level above 5 kHz

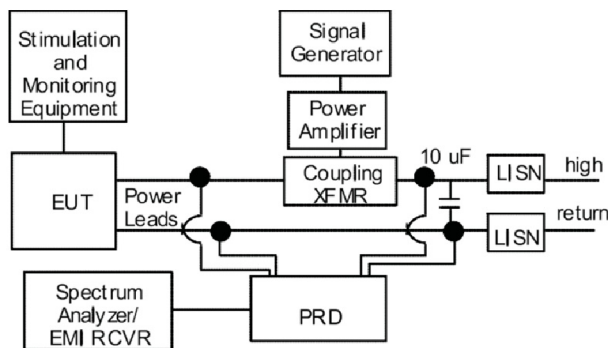

FLAT FREQUENCY RESPONSE
TRANSDUCER FACTOR

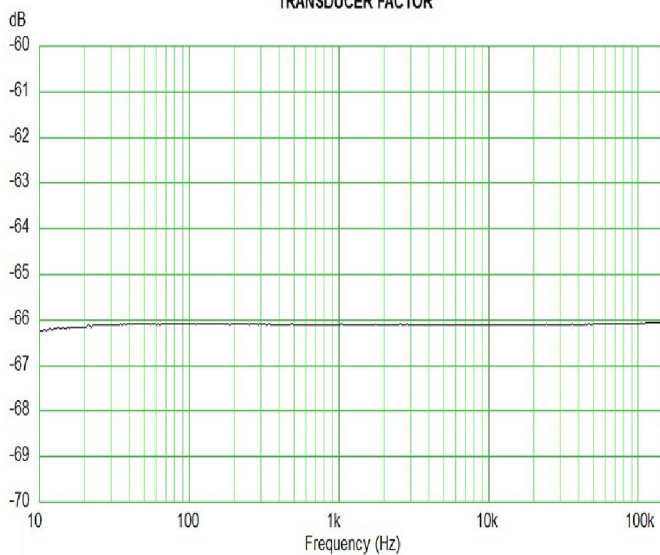

CS101 RESPONSE
TRANSDUCER FACTOR

